

Coil Development for Electromagnetic Corner Fill of AA 5754 Sheet^{*}

J. Imbert¹, M. Worswick¹

¹ Department of Mechanical and Mechatronics Engineering, University of Waterloo, Waterloo, Ontario, Canada

Abstract

Electromagnetic (EM) forming is a high-speed forming process that uses the forces induced on a conductive workpiece by a transient high frequency magnetic field to form the workpiece into a desired shape. It has been reported by several researchers that EM forming (EMF) increases the formability of hard-to-form aluminum alloy sheet under certain circumstances. EMF can be combined with conventional forming (e.g. stamping) operations to create a hybrid forming operation that exploits the strengths of each process. One such operation is the “corner fill” operation, which consists in pre-forming sheet using conventional forming and then using EMF to reduce the radii of different features on the part to values that could not be obtained with conventional forming. This paper describes the development of a coil used for a hybrid operation that consisted on pre-forming AA 5754 1 mm into a v-shape with a 20 mm outer radius and then reducing or “sharpening” the radius to 5 mm using EMF. The coil is one of the most important components of an EMF operation, since it is the means of delivering the energy to the workpiece. Coils are subjected to very high stresses and are typically the element of an EMF operation that will fail first. One successful and four unsuccessful coils designs are presented. The successful coil was a single loop design, with the section closest to the part narrowed to increase the current density. The simplicity of the shape was chosen for its current flow characteristics and for its structural strength.

Keywords

Forming, high, speed

^{*} The authors would like to thank the Natural Science and Engineering Research Council of Canada and the Ontario Research Fund for their financial support

1 Introduction

Electromagnetic (EM) forming is a high-speed forming process that uses the forces induced on a conductive workpiece by a transient high frequency current to form the workpiece into a desired shape. EM forming (EMF) can be combined with conventional forming (e.g. stamping) operations to create a hybrid forming operation that exploits the strengths of each process. One such operation is the “corner fill” operation, which consists in pre-forming sheet using conventional forming and then using EMF to reduce the radius of different features on the part to values that could not be obtained with conventional forming. Figure 1 illustrates the process with the corner fill operation used for this research, in which a sheet is formed with a conventional tool comprising a die and a punch and then an EMF operation is used to sharpen or “fill” the corner.

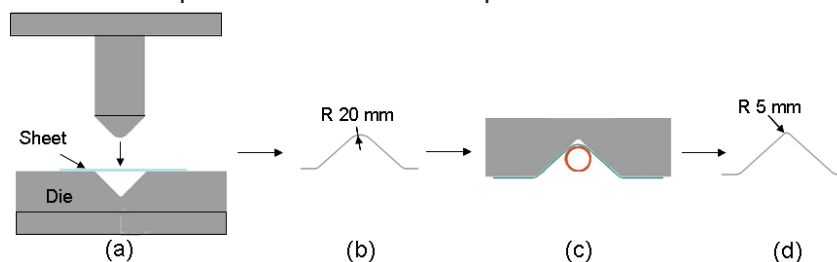

Figure 1: Schematic of the hybrid forming operation which consists of a) conventional forming to produce b) a pre-formed blank with a radius of 20 mm that is then subjected to c) an EM corner fill operation to produce d) the final sample shape.

Despite the interest shown on this subject by researchers in both academia and industry, there have been few works published on the subject of hybrid forming. Daehn et al. [1] determined it was feasible to form the sharp features of the aluminum panel using EMF. Oliveira [2] studied corner fill numerically for an axi-symmetric geometry and found that the induced force distribution had a significant effect on the final shape of the material in the corner. Psyk et al. [3,4] studied sharpening of a feature on a representative full-scale automotive stamping and found that the process was feasible. Liu et al. [5] showed that EMF could be used for sharpening corners on axisymmetric deep drawn parts, similar to the ones used in LDR tests. Golovashchenko [6] conventionally pre-formed blanks and then used EM and electrohydraulic forming to sharpen the corners. It was reported that EMF could be used to form two dimensional radii, but not three-dimensional ones, where electrohydraulic forming was required [6].

The hybrid operation reported here consisted of pre-forming the material using a v-channel tool to an outside radius of 20 mm while allowing draw-in and then reducing the radius to 5 mm using EM forming without draw-in. Figure 2 shows the ideal pre-formed and final sample shapes used for this work. The experiment was designed so that the pre-formed part could not be formed to a 5 mm outer radius using a conventional stamping operation if the material was not allowed to draw into the die. This simulated a multi-step forming process in which the material within a larger part is constrained from drawing-in to sharpen a corner feature, in which case an EM forming step can be a means to sharpen corner radii. The results of the corner fill experiments have been reported by Imbert [7] and Imbert and Worswick [8]. A sample formed using the successful coil design is shown in Figure 3.

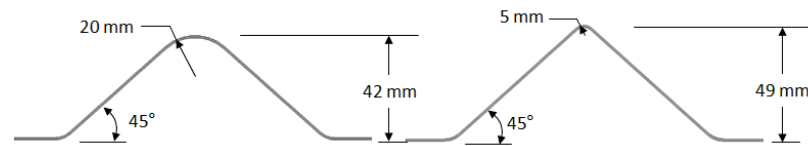

Figure 2: Cross section of the experimental parts in the 20 mm radius perform and ideal 5 mm outer radius final shape.

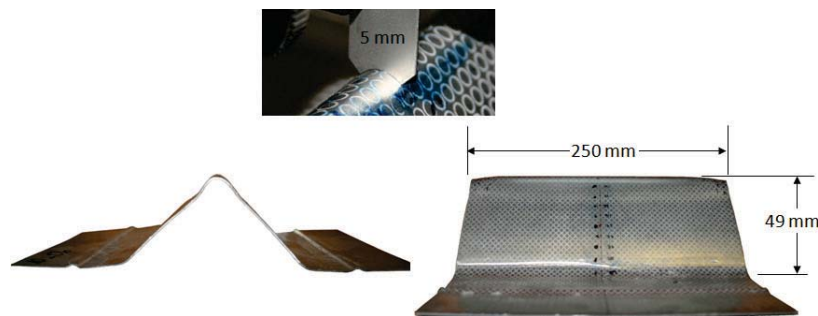

Figure 3: Sample formed with the successful coil design. The inset shows a 5 mm radius gauge placed on the formed part.

As with any EMF (or EM welding) process, the coil is a crucial component of the process, since it is the means of delivering the energy to form the workpiece. Coil design is a significant challenge, due in great part to the conflicting requirements of high conductivity, which calls for the use of high conductivity materials, and high strength, which is challenging since high conductivity materials tend to have relatively low structural strength. Many of the design challenges faced when designing coils for sheet forming applications were described by Golovashchenko [9] and Golovashchenko et al. [10], where re-enforced coils were proposed as a solution. Some applications require creative coil designs to meet the requirements, like the ones presented by Zhang et al. [11] for EM welding.

The remainder of this paper will focus on the coils tested during the development and realization of the experiments. General coil requirements will be discussed first, followed by descriptions of the unsuccessful coil designs and, finally, a description of the successful design. In this paper the authors wish to share the development of a coil design for a specific operation that is representative of possible future commercial applications. The coils presented here were developed as part of a formability research program, not a coil design program, and thus the coil design process involved some significant trial and error. This was the result of trying to achieve a successful corner fill operation with the constraints imposed by existing equipment, the sample geometry, manufacturing capability, budget and schedules. Numerical simulations were used to aid in coil design with some success and the reader is referred to Imbert [7] and Imbert and Worswick [8] for details on the simulations. Although these were laboratory scale experiments, similar constraints would likely be present in a commercial corner fill operation.

2 Coil Requirements

Figure 3 shows a diagram with the main requirements that will determine the final design of a successful coil:

It can make the part: the most critical condition is that the coil produces the part or feature that it is intended to make.

Durability: the coil must be able to be used enough times to make it economically feasible for the operation. For production applications, this also includes considering the thermal stability of the coil during repetitive short cycle part production [10].

Manufacturability: the coil must be able to be made by a process that is not overly complicated and/or expensive.

Cost: the coil has to be economical.

Energy delivery: it must deliver the energy as efficiently and usefully as possible.

Effect on process modelling: modelling of EMF will be relatively resource intensive for the foreseeable future, thus issues such as element size and its effect on run time and memory use must be taken into account.

Safety: all applicable safety standards must be met. Protection from electrical currents is the first concern, but issues like noise generated by arcing may have to be seriously considered.

Installability: coils, with their connectors and insulation, have to fit within the machine or the tool that is being used.

For the corner fill operation studied the coil had to deliver as much energy as possible to the corner area, while maintaining its structural integrity. Due to the relatively low energy capacity of the MPG, the coil had to be as efficient as possible, which for this application meant the very low impedance, to obtain the highest peak current. Finally, the coil had to fit within the geometric constraints imposed by the pre-formed samples and the connectors for the MPG.

The experiments were carried out in the University of Waterloo's EM forming and welding laboratory. The laboratory consists of a Pulsar MPW 20 – Research Edition Magnetic Pulse Generator (MPG) in conjunction with a 100 ton hydraulic press. The MPG has a nominal maximum energy capacity of 20 kJ and a maximum charging voltage of 9,000 V. The machine's capacitance is 539.7 μF , its inductance 24.35 nH and its resistance 2.98 m Ω . The nominal discharge frequency using a shorting bar across the output terminals of the capacitor bank was 24.5 kHz [12].

The hybrid process was described above and is illustrated in Figure 1. The corner fill apparatus was installed on a hydraulic press, as shown in Figure 4 in the open position, with the coil design used for the experiments. Cables were used to connect the coil to the MPG, via the connector. The coil was mounted on a PVC base that isolated it electrically from the press to minimize the effect on the electromagnetic fields produced by the coil/workpiece system (Figure 4). The coil was connected to the MPG by bolting the ends of the rods to the connector. A detailed description is provided by Imbert [7].

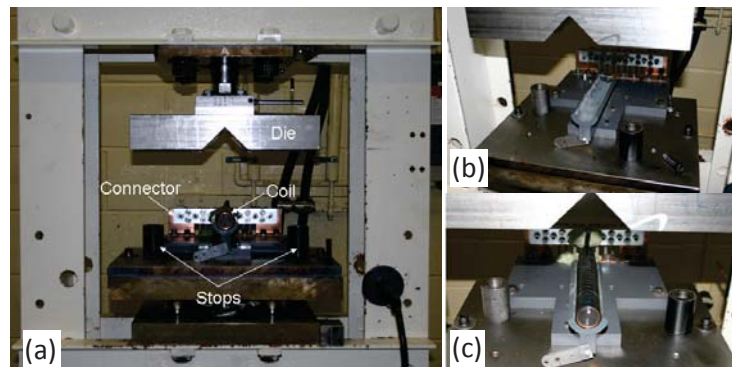

Figure 4: EM corner fill apparatus showing a) the coil and die with a partial view of the press a), the apparatus b) without, and c) with the coil.

3 Unsuccessful Coil Designs

Four coil designs were tested that proved inadequate for the task, before a successful design was developed. They are presented here in chronological order of development. The first design was the simplest concept and what many would consider for a first attempt, a helical coil. A coil made from wound 12.7 mm (0.5 in) copper cable was tried with no success since the sample sheets did not show any deformation. A simulation of the coil illustrates one reason why the design was not successful (Figure 5). The current flows on the inside of the coil, thus taking it away from the workpiece and reducing the induced forces. The fact that a significant amount of the current would travel on the inside of the helix was known, but this the design was tried because in principle it met many of the requirements; it was easy to make, affordable, easily installed, easy to model, and apparently safe. Where it failed was that it could not make the part, because it could not deliver the energy to where it was needed.

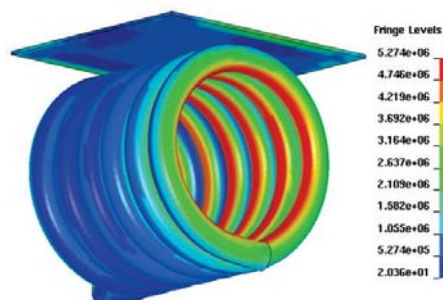

Figure 5: Simulation of a helical coil with a workpiece. Contours are of current density.

A coil made from wound copper wire was designed and tested (Figure 6). The coil was based on an axi-symmetric design presented by Oliveira [2] that provided an area of relative uniform current distribution on the workpiece by moving the dead-spot away from the area to be formed. To achieve this result in a coil for a linear corner fill, copper wires were shaped in the form of concentric U shapes so that all the wires at the top of the coil would have current flowing in the same direction. The current would flow back on the side of the coils, thus moving the dead spot away from the workpiece. Figure 6 also shows an idealized coil with the current directions.

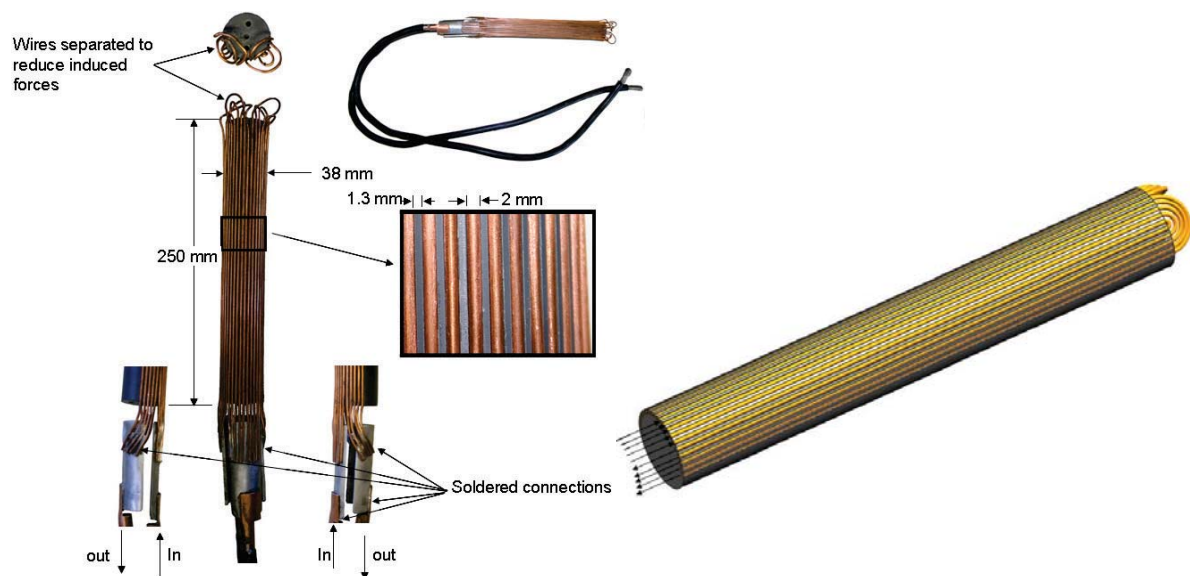

Figure 6: Wound coil with details of the soldered connections and idealized version of the coil without connectors showing the current direction.

The wires were wound on a PVC cylinder with groves cut into it to support the wires and prevent any lateral movement. To connect the coil to the MPG, the wires were soldered to aluminum leads (one each for current in and out) and to each of these a cable was in turn soldered that connected the coil to the MPG connector. For insulation, vinyl tape was wrapped around the coil. The soldered connection proved to be the weakest point of this design, which was not successful due mainly to structural weakness. Soldered connections did not prove adequate for laboratory testing and it is highly unlikely that they could be used in an industrial setting. The soldered wire joints could not resist loads generated and failed typically with one pulse. This design was also very hard to realize with significant amounts of time being required to form and install the wires, and to solder them to the connectors. This coil was not durable and was very hard to manufacture. The durability issue was such that it was not successfully tested, so it was never determined whether it could form the part. This design was labour intensive and required precision machining, which made the design costly. There were health and safety issues associated with the coil since every time it failed a loud bang was generated, which did not cause any problems since all the personnel involved wore ear protection, but could be an issue in an environment where it was not required. Subsequent experience also showed that the energy was not properly focused in the corner radius. This design illustrates the impact of the coil design on modelling, since the solid elements used to mesh the wire were in the order of $0.2 \times 0.2 \times 1$ mm, which are very small and would increase the computation time in an explicit FEM code. Also, the size ratio is not ideal, since 1 mm length was used to try and reduce the number of elements.

A single loop coil design was tested that consisted of a half cylinder with a slot cut into it. The first prototype of this coil was made from aluminum and is shown in Figure 7. The slot provided a U-shaped path for the current; due to this, the coil was referred to as the U coil. The coil was mounted on a polycarbonate rod for structural support. The

connectors for the aluminum U coil were soldered to the ends. The coil was wrapped in vinyl tape for insulation.



Figure 7: Aluminum U coil.

The aluminum coil provided enough energy to produce significant deformation on a sample sheet, but not enough deformation to achieve the desired reduction in radius. A copper version was made to try and improve the conductivity and thus the induced forces generated. The copper U coil is shown in Figure 8. The connectors for this coil were welded to increase structural strength. Vinyl tape was wrapped around the coil for insulation. After four tests, the coil was plastically deformed by the forces induced, as can be seen in Figure 8. The slot in the coil expanded from 5 mm (Figure 7) to a maximum of 9 mm. Re-enforcements for the coil were designed and partly built, but not implemented since a better design was developed. Another disadvantage of this coil was that the connecting cables were close together and repelled each other during the tests, stressing the connection area between the cables and the U coil. During the development of this design copper welds were used to join the cables to the main coil, via copper leads. Copper welds significantly improved the strength of the connections and were used in the successful design.



Figure 8: Copper U coil after four tests.

The U coil design showed promise mainly because it concentrated the energy in the area of the slot and thus had the potential to form the part successfully. However, the durability was poor, mainly due to the strength of the materials. Re-enforcements could have been made, but they would have resulted in increased cost. The main advantage of this coil was its manufacturability. It was easy to make, especially once welding with copper rod was implemented. The U coils were also easy to install and did not present any behaviour during testing that would have caused safety concerns.

The coil design that led to the final working coil is very similar to the final design and is shown in Figure 9. The coil was a single loop design, with the part of the loop that provided the return path used to form the feature (Figure 10 a). This design has the structural, manufacturability, cost, installability and modelling advantages as the final design. However, the coil could not form the desired feature. The coil failed because it could not deliver the energy in a way that would form the part. This was the result of the

width of the coil, which has an area wider than the equivalent area in the successful design, which led to a lower current density and lower induced forces on the workpiece. Also, part of the induced forces acted directly against material supported by the die and produced no deformation (Figure 10-a). A less obvious, but very important, difference was that the connectors for this coil were soldered to the coil and not welded. This resulted in a significantly weaker joint that failed during testing.



Figure 9: Coil that led to the successful design.

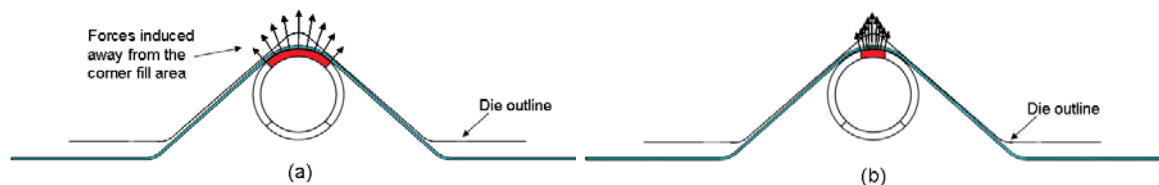

Figure 10: Simplified induced force distribution for a) the unsuccessful and b) successful coil design.

4 Successful Coil Design

Illustrations of the successful coil are shown in Figure 11. The coil is very similar to the last coil described, but with the section that is closest to the part narrowed to increase the current density, as illustrated in Figure 10-b and Figure 11-a,b (for more details on the numerical results, see [8]). The simplicity of the shape was chosen not only for its current flow characteristics, but also because it had significant structural strength once it was assembled for use with the connectors and an internal support. Part of the structural strength came from the clamping pressure applied by the press, which acted in such a way as to prevent the coil from moving.

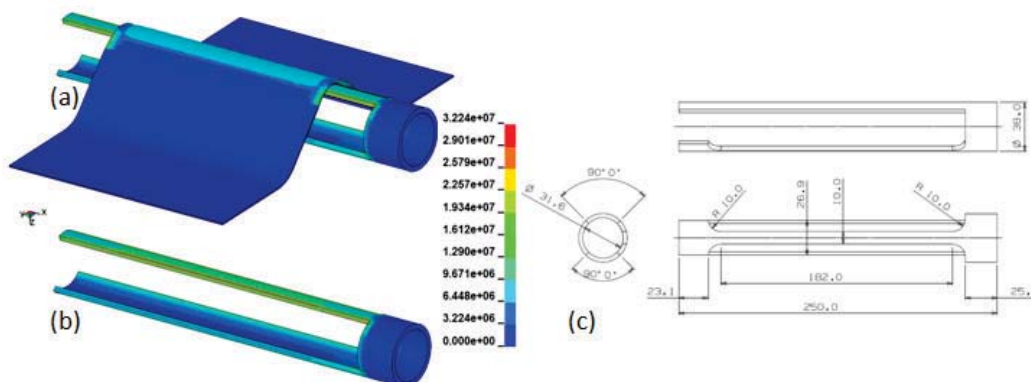

Figure 11: The successful coil shown with the predicted current density a) with and b) without a sample. A detailed drawing is shown in c). All dimensions in mm.

Solid copper rods were used to connect the coil to the connectors to the MPG to increase the structural integrity of the coil. Cables were tried first but during each pulse the cables were accelerated resulting in dynamic loads on the soldered joints that caused their failure. The rods were stiffer than the cables and they could be welded to the coil using an TIG welding process, which resulted in a much stronger connection. The space within the coil was filled with a polycarbonate rod for structural support. Figure 12 shows the coil with the connectors and the polycarbonate rod. The whole coil assembly was insulated from the sheet and the rest of the apparatus. To insulate the coil, it was wrapped in two layers of vinyl tape with a layer of polyamid Kapton® in between. The total thickness of the insulation was approximately 1 mm. The connecting rods were wrapped in vinyl tape to prevent arcing between the rods and the metal in the MPG connector and the die.

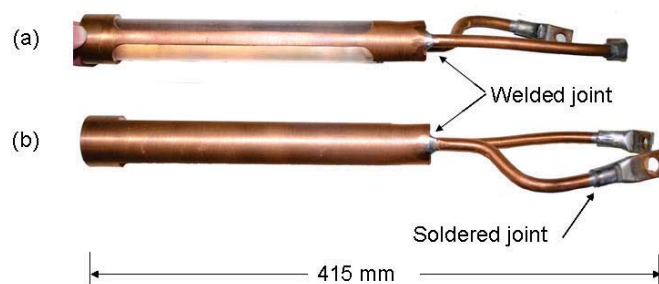

Figure 12: a) top and b) bottom view of the coil showing the types of joints used. The material that can be seen inside the coil in a) is a polycarbonate rod.

This coil met all the requirements that are outlined above. Most importantly it made the part and was durable enough so that it did not have to be replaced for the duration of the experimental program, which consisted of 37 tests, 20 of which were performed at 7,500 V. No damage was observed on the coil after the experiments were completed. A rough estimate of the efficiency of the coil was calculated by using the nominal charge energy of 15.1 kJ and the predicted plastic work expended during forming, which resulted in an efficiency of 2.5% [7]. If the power calculated from the current profile is used, the efficiency was 3.2% [7]. The estimated efficiency is low, but it is comparable with the estimates presented by Belyy et al. [13].

This design proved suitable for the experimental program, but it would have to be developed further for larger scale production. The energy delivery efficiency and the durability would have to be improved to make it more suited for production. Providing for a return path for the induced current could improve the efficiency of the coil [14]. The durability could be improved by providing a stronger polymer base that could support the lateral loads on the part of the coil that is interacting with the workpiece. The energy delivery efficiency could be improved by reducing the impedance of the connectors, for example by having a form of concentric connector, analogous to low impedance cables.

5 Conclusions

One successful and four unsuccessful coil designs for an EM corner fill operation were presented in this paper. The coils presented show the evolution of the design and how it progressed to meet the necessary requirements for an EM forming coil. The paper shows

how all the requirements must be met for a coil to be successful and how basic concepts such as strength or materials, manufacturability and cost can play a significant role, even in a research environment. In the end the coil must make the part, but it has to be able to deliver the forming energy, manufacturable, affordable, installable, durable, safe and, increasingly, amenable to modelling.

References

- [1] Daehn, G.S.; Vohnout, V.J. and DuBois, L., "Improved Formability with Electromagnetic Forming: Fundamentals and Practical Example", <http://www.ecr6.ohio-state.edu/~daehn/overview/index.htm>, Ohio State University, date not available.
- [2] Oliveira, D.A. *Electromagnetic Forming of Aluminum Alloy Sheet: Experiment and Model*. Masters of Applied Science thesis, University of Waterloo, 2002.
- [3] Psyk, V.; Beerwald, C.; Henselek, A.; Homberg, W.; Brosius, A. and Kleiner, M., 2007. Integration of Electromagnetic Calibration into the Deep Drawing Process of an Industrial Demonstrator Part, *Key Engineering Materials*, v. 344, 435-442.
- [4] Psyk, V.; Risch, D.; Beerwald, C.; and Tekkaya, A.E., 2008. "Investigation of Combined Electromagnetic and Conventional Forming", *IDDRG 2008 Int. Research Conf.*, Olofstrom, Sweden, Asnafi, N. ed., 487-498.
- [5] Liu, D.; Li, C. and Yu, H., 2009. Numerical Modelling and Deformation Analysis for Electromagnetically Assisted Deep Drawing of AA 5052 Sheet, *Trans. of the Nonferrous Met. Soc. of China*, v. 19, 1294-1302.
- [6] Golovashchenko, S.F., 2010 "Electrohydraulic Forming for Automotive Applications", *4th Int. Conf. on High Speed Forming*, G. Daehn ed., March 9-10,, Columbus, OH.
- [7] Imbert, J., 2010. Hybrid Electromagnetic Forming of Aluminum Alloy Sheet. University of Waterloo Ph.D. thesis, <http://uwspace.uwaterloo.ca/handle/10012/5517>.
- [8] Imbert, J and Worswick, M, 2011. Electromagnetic Reduction of Pre-Formed Radius on AA 5754 Sheet. *J. Mat. Proc. Tech.*, v. 211, 896-908.
- [9] Golovashchenko, S., 2007. Material Formability and Coil Design in Electromagnetic Forming, *J. Mat.Eng. Per.*, v.16, n. 3, 314-320.
- [10] Golovashchenko, S., Besonov, N., Davies, R., 2006. "Design and Testing of Coils for Pulsed Electromagnetic Forming", *2nd Int. Conf. on High Speed Forming*, M. Kleiner ed., March 20-21, Dortmund, Germany, 141-151
- [11] Zhang., Y., Babu. S., Daehn, G.S., 2010. "Impact Welding in a Variety of Geometric Configurations", *4th Int. Conf. on High Speed Forming*, G. Daehn ed., March 9-10 2010, Columbus, OH, 97-107
- [12] Pulsar. Contact information currently unavailable.
- [13] Belyy, I.V.; S.M. Fertik and Khimenko, L.T., 1977. "Electromagnetic Metal Forming Handbook". Translation by Altynova, M.M. 1996, available from the Hyperplastic Forming Consortium at the Ohio State University.
- [14] Personal communication with Prof. G, Daehn, September, 2010.